

STANDARD
MODEL NO. MHC-D1-500

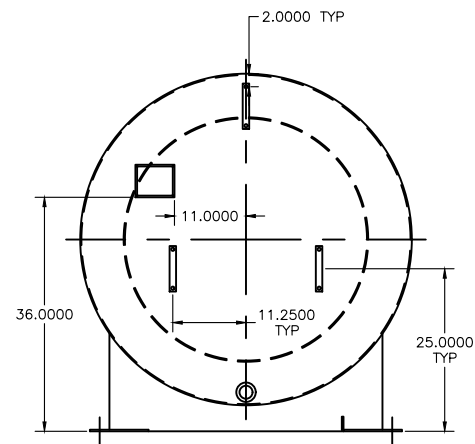

LEFT END VIEW

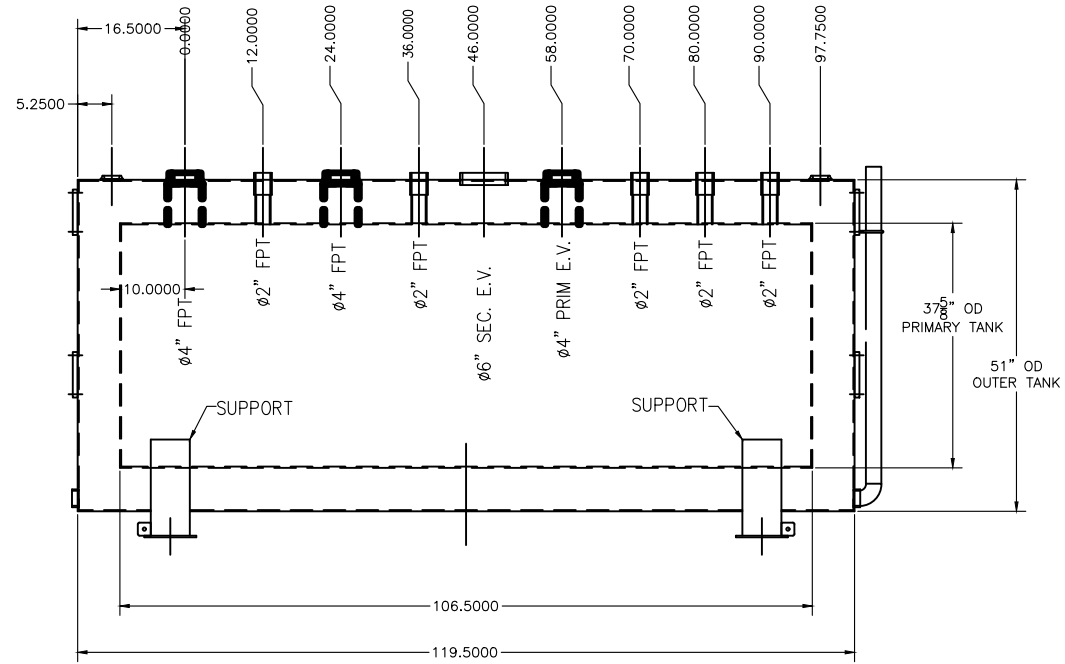

ELEVATION VIEW

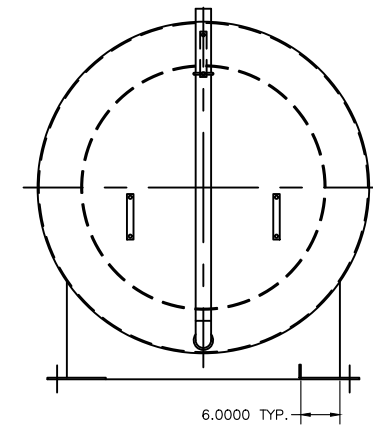

RIGHT END VIEW

CONNECTION DATA	PRIMARY TANK	SECONDARY TANK
Ø 2" FPT.	Ø 2 7/16"	Ø 2 7/8"
Ø 2" TNK FLNG.	-	Ø 2 3/4"
Ø 4" FPT.	Ø 5 5/8"	Ø 5 3/16"
Ø 4" PRIM. E.V.	Ø 5 5/8"	Ø 5 3/16"
Ø 6" SEC. E.V.	-	Ø 7 1/2"
FITTING SCHEDULE		

DESIGN: FABRICATED PER UL-142 & 2085, SWRI (SOUTHWEST RESEARCH)
 INSPECTION: MODERN WELDING COMPANY
 MATERIAL: MILD CARBON STEEL (UNLESS NOTED)
 (INTERNAL): SURFACE PREP - N/A
 COATING - N/A
 (EXTERNAL): SURFACE PREP - SSPC-SP6 (COM. BLAST)
 COATING - PRIMER & PAINTED FINISH
 OPERATING PRESSURE: ATMOSPHERIC
 PRESSURE TEST: 3-5 PSI AIR W/ SOAP TEST
 INTERSTITIAL: PERLITE CONCRETE MATERIAL BETWEEN PRIMARY & SECONDARY

GENERAL NOTES

THIS DRAWING IS FOR ILLUSTRATION PURPOSES ONLY AND IS NO TO BE RELIED UPON FOR ANY OTHER PURPOSE. NO WARRANTY OF MERCHANTABILITY, OF FITNESS FOR A PARTICULAR PURPOSE OR OF ANY OTHER KIND, EXPRESSED OF IMPLIED, IS HEREBY MADE.

 MODERN WELDING COMPANY, INC.

"SUPERVAULT" MH-PROTECTED AST
MHC-D1-500

TANK NOM. CAPACITY: 500 GALLONS

DWN. BY:	SCALE: NONE	DATE:	DWG NUMBER
APR. BY:	JOB NO.:JOB	SHEET: 1 of 1	