

STANDARD MODEL NO. MHC-D5-6000

CONNECTION DIA.	PRIMARY TANK	SECONDARY TANK
Ø2" FPT	Ø2 7/16"	Ø2 7/8"
Ø2" TANK FLNG.	-	Ø2 3/4"
Ø4" FPT	Ø5 5/8"	Ø5 3/16"
Ø6" FPT	Ø6 11/16"	Ø7 1/2"
Ø8" SEC. E.V.	-	Ø9 3/4"
Ø8" PRIM E.V.	Ø8 3/4"	Ø9 3/4"
Ø20" MANWAY	Ø25 9/16"	Ø25 9/16"

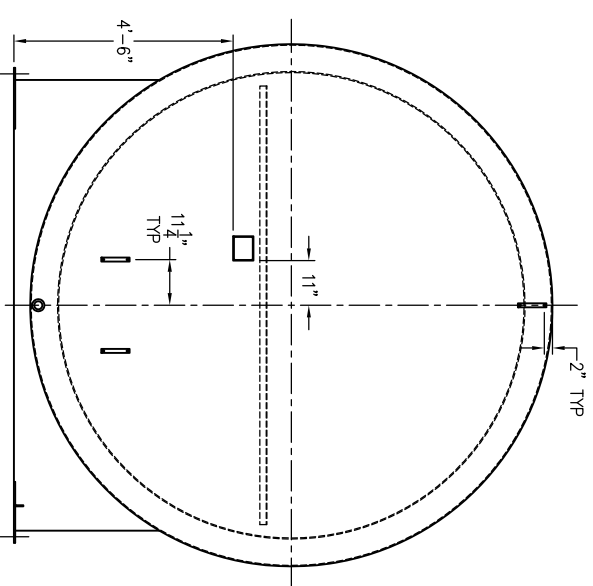

LEFT END VIEW

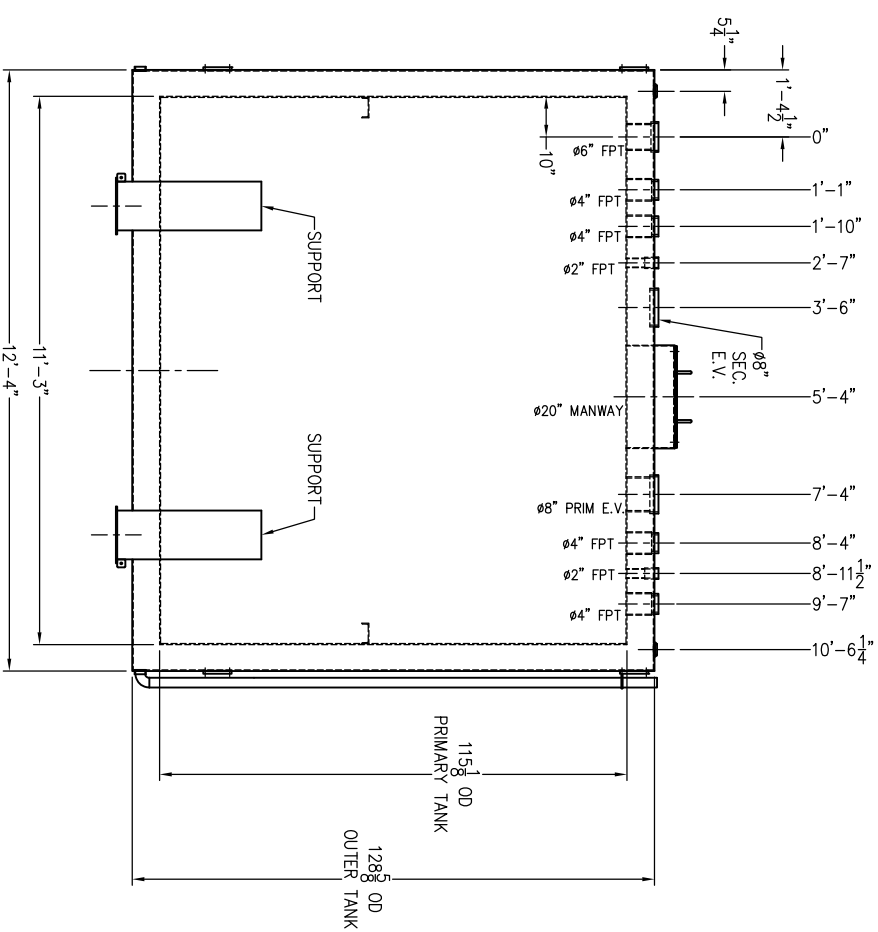

ELEVATION VIEW

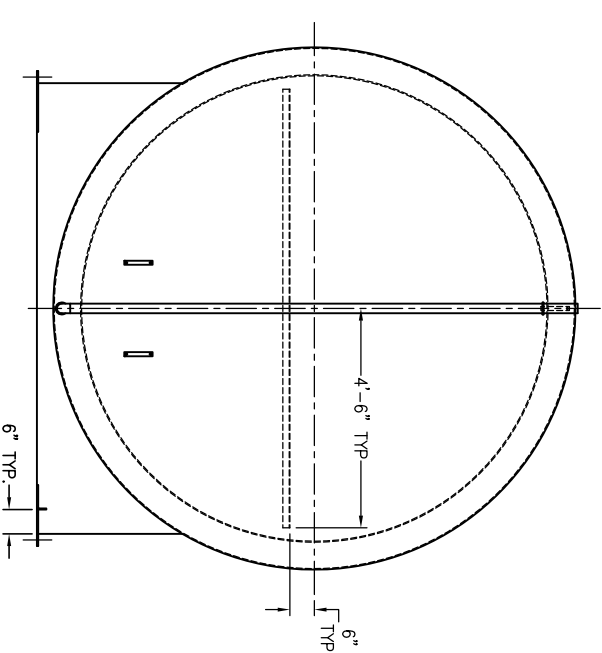

RIGHT END VIEW

SHOP NOTES

1. COVER ALL OPENINGS BEFORE SHIPPING.
2. STRADDLE CENTER LINES OF ALL FLANGES UNLESS OTHERWISE SPECIFIED.
3. GRIND & DEBURR ALL EDGES.
4. MASK GROUNDING LUG, (ITEM #4) BEFORE PAINTING.

NO.	REVISION	DATE	BY
Δ-	-	-	-

NO. REQUIRED (1) ONE ITEM NO. NONE

modern custom fabrication
fresno california

P.O. Box 11925 • 2421 E. California Ave. • Fresno, California 93721
Ph: (559) 264-4741 OR 800-800-TANK • Fax: (559) 237-3413



Supervault Inc.
SUPERVAULT MH-PROTECTED ABOVE GROUND STORAGE TANK

MODEL NO. MHC-D5-6000

CUSTOMER SIGNATURE: _____

DATE: _____

SHOP ORDER NO.: _____

EST. STEEL TANK WEIGHT: _____

VENTING CAPACITY

PRIMARY: 296,800 SCFH

SECONDARY: 333,300 SCFH

DRAWN BY:	SCALE:	SHT.
JJK		1 OF 1
CHECKED BY:	DATE:	
DWG./JOB NO.:		