

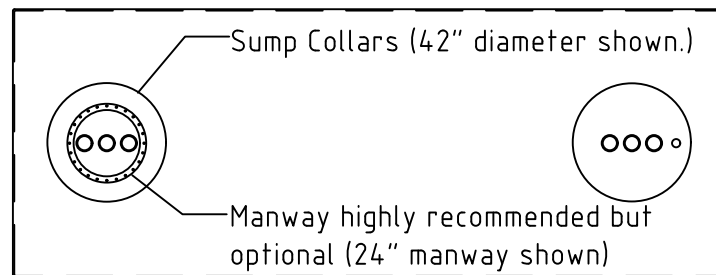

END VIEW

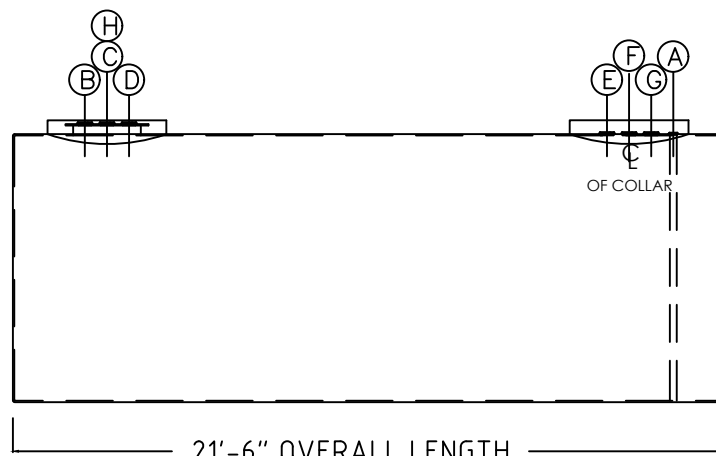

PLAN VIEW



ELEVATION VIEW

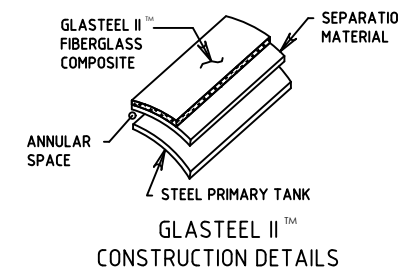

INTERIOR: BARE, CLEAN OF DEBRIS
EXTERIOR: F.R.P.

MARK	QTY.	SIZE	TYPE	REMARKS
H	1	24"		MANWAY
G	1	4"	FNPT	
F	1	4"	FNPT	
E	1	4"	FNPT	
D	1	4"	FNPT	
C	1	4"	FNPT	
B	1	4"	FNPT	
A	1	2"	FNPT	MONITOR
SCHEDULE OF OPENINGS				

DESIGN : FABRICATED PER UL 1746 SPECIFICATIONS
MEETS NFPA 30 & 31 REQUIREMENTS
MEETS EPA 280.20 REQUIREMENTS
METHANOL COMPATIBLE PER RULE 1170

INSPECTION : MODERN WELDING COMPANY
MATERIAL : MILD CARBON STEEL (UNLESS NOTED)
INTERNAL SURFACE PREP.-CLEAN OF DEBRIS
EXTERNAL SURFACE PREP - SSPC-SP6
COATING : 100 MIL. MIN. F.R.P.
OPERATING PRESSURE : ATMOSPHERIC

THIS TANK ARRIVES AT THE JOBSITE UNDER VACUUM AND DOES NOT REQUIRE FURTHER INTEGRITY TESTS. IF JOBSITE AIR PRESSURE TEST REQUIRED THE PRIMARY (INNER) TANK MAY BE PRESSURIZED UP TO 5 P.S.I. THE SECONDARY (OUTER) TANK MAY BE TESTED BY VACUUM ONLY. THE OUTER TANK RECEIVES A 35,000 VOLTS HOLIDAY TEST AT THE FACTORY

GENERAL NOTES

THIS DRAWING IS FOR ILLUSTRATION PURPOSES ONLY AND IS NOT TO BE RELIED UPON FOR ANY OTHER PURPOSE. NO WARRANTY OF MERCHANTABILITY, OF FITNESS FOR A PARTICULAR PURPOSE, OR OF ANY OTHER KIND, EXPRESSED OR IMPLIED IS HEREBY MADE.

MODERN WELDING COMPANY, INC.

GLASTEEL II JACKETED UNDERGROUND TANK

TANK NOM. CAPACITY : 8,000 GALLON

DWN. BY	DATE:	SCALE: NONE
CHK. BY	JOB NO.	DWG. NO.
APR. BY	P.O. NO.	SHT. NO. 1 OF 1