

R971-07

INSTALLATION INSTRUCTIONS

JULY 2007
1.0 EXCAVATION AND BEDDING

- 1.1 The bottom of the excavation shall be covered with a minimum of 12 inches (305 mm) of bedding, suitably graded and leveled. Bedding and backfill material surrounding the tank, to a width and depth of 12 inches (305 mm) all around the tank, shall be clean material.
- 1.2 Where anchoring by means of a concrete pad, the tank shall not be placed directly on the pad. Bedding material at least 6 inches (152.4 mm) deep must be spread evenly over the dimensions of the pad to separate the tank from the pad.

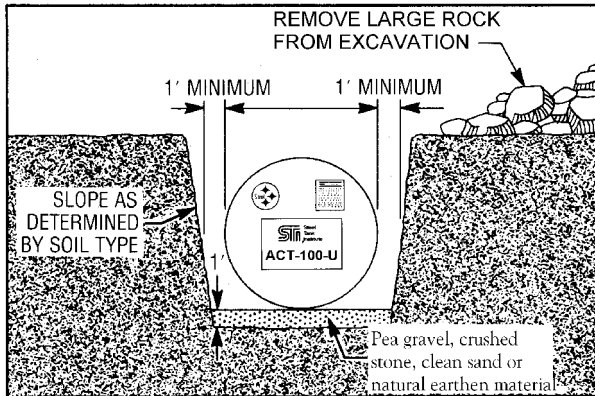

- 1.3 Bedding and backfill material shall consist of homogenous pea gravel, crushed stone, clean sand or natural earthen materials. Crushed stone, clean sand and natural earthen materials shall be capable of passing 100% through a 1/2 inch (13 mm) sieve and no more than 12% by dry weight through a #200 sieve (0.0029 inch (0.0754 mm)). Pea gravel shall be no larger than 3/4-inch (19 mm). The materials shall be free of all foreign materials, such as but not limited to, bricks, metals, concrete and plastics.
- 1.4 The backfill material may be from the tank site if it meets this description, or it may be delivered to the site from another source.
- 1.5 Sand or natural earthen materials used as backfill shall be placed into the excavation in 12-18 inch (305-458 mm) vertical lifts, compacted after each lift, at least 60% up the vertical height of the tank.

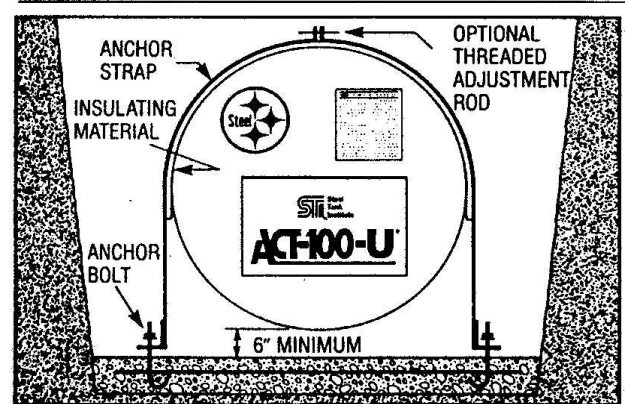

- 1.6 If earthen material from the site, or other earthen material, is to be used as bedding or backfill material, a minimum of four 1 cu.ft. samples shall be taken from different locations which are representative of the backfill material and the site. Samples shall be sieved to determine if the material complies with this specification.
- 1.7 In a tidal area, the tank "bedding" material shall be crushed stone or pea gravel. Sand and natural earthen material may be used only if measures are taken to prevent washout of material during the design life of the system.
- 2.0 AIR TEST AT JOB SITE**
- 2.1 The temporary plugs and thread protectors installed by the manufacturer shall be removed. Apply compatible, non-hardening pipe sealant to internal bushing threads. Permanent metal plugs shall be installed at all unused openings.
- 2.2 The nylon bushings in the tanks shall not be removed from the unused openings. Plugs used to temporarily seal the tank for the aboveground air test, but later removed for pipe installation, shall not be over-tightened. Do not cross thread or damage the nylon bushings when replacing plugs or installing required tank piping.
- 2.3 Test pressure shall be maintained at, but not exceed, 5 psig (34.5 kPa) while a soap solution is applied to the area of pipe connections and welds.

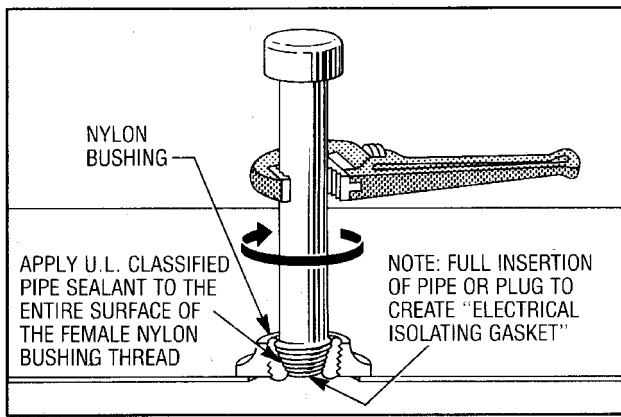

with a holiday detector set at a minimum 10,000 volts.

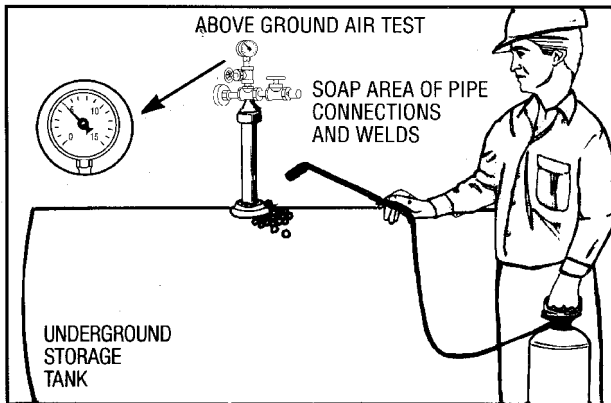
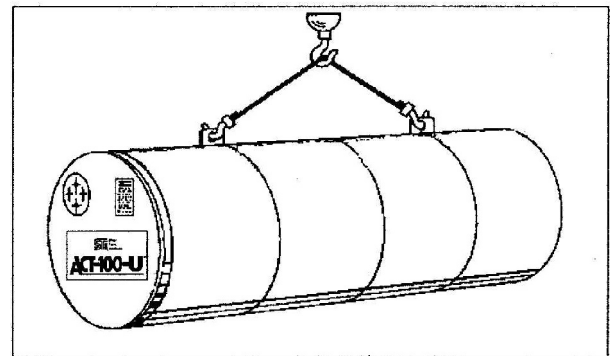

- 3.3 Coat all holidays, damaged cladding, and/or exposed steel surfaces using touch-up kit furnished by tank supplier. Follow manufacturer's instructions for mixing and application of resin. (See Section 9 for touch-up procedures.) All holidays shall be re-tested at 10,000 volts.

4.0 TANK HANDLING

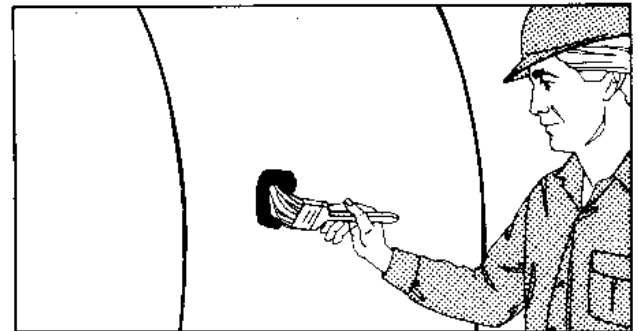

- 2.4 Dual wall tanks will require different air pressure testing procedures. Do not connect a high pressure air line directly to the interstitial monitoring port. A factory applied vacuum within the interstitial space can be used in lieu of, or in addition to, the air test procedure. Consult tank fabricator for air test recommendations. Do not apply a vacuum to the primary tank or a single wall tank. PEI/RP 100-00 also provides guidelines.
- 2.5 Take necessary safety precautions during air tests. Do not leave tanks unattended while under pressure. Avoid standing at the head of the tank, especially while applying air pressure. Use an air-pressure relief valve.

3.0 TANK INSPECTION

- 3.1 This tank is shipped with protective material attached. This material must remain on the tank and shall not be removed. Before placing the tank in the excavation, all dirt clods and similar foreign matter shall be cleaned from the surface of the tank. Set the tank on the ground such that the protective material is between the tank and the ground.
- 3.2 Visually inspect the tank for damage. Pay particular attention to areas where cladding has been gouged or abraded. Mark all areas which appear damaged for repair. Any section of the cladding, which has been damaged beyond the surface of the cladding, shall either be repaired or spark tested. Spark testing shall be done

- 4.1 Controlled off-loading of the tank shall be allowed.
- 4.2 Equipment to lift the tank shall be of adequate size to lift and lower the tank without dragging or dropping to prevent damage to the tank or the coating.
- 4.3 Tank shall be carefully lifted and lowered off of the truck and into the excavation hole by use of cables or chains of adequate length attached to the lifting lugs provided. A spreader bar should be used where necessary. Under no circumstances shall chains or wire rope slings be used around the tank shell.

5.0 ANCHORING

- 5.1 High water tables or partially flooded excavation sites exert significant buoyant forces on tanks. Buoyant forces are partially resisted by the weight of the tank, the backfill and the pavement atop the tank. Additional buoyant restraint when required, shall be obtained by using properly designed hold-down straps in conjunction with concrete hold-down pads or deadman anchors. The use of steel cable or round bar as hold-down straps is prohibited.

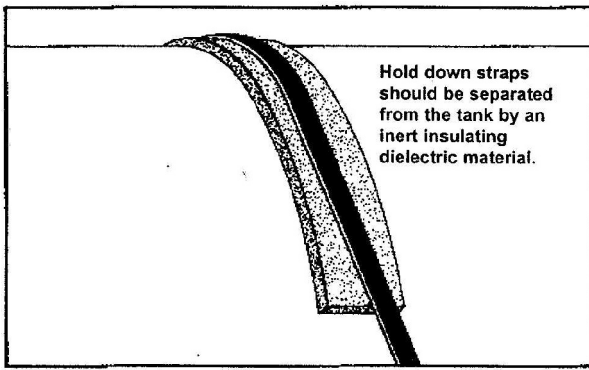

7.0 ELECTRICAL ISOLATION

- 7.1★ This tank requires venting. Refer to applicable local codes and PEI RP-100 for proper installation.
- 7.2 All openings shall be isolated where electrical accessories will be installed such as submersible pump, monitoring equipment and all other grounded electrical devices.
- 7.2.1 Prior to backfilling over top of tank, all openings shall be visually inspected to assure that the dielectric isolation (nylon bushings or flange gaskets), where furnished, remain in place. Where flanged openings have been used, isolation of the flange gaskets shall be confirmed with a continuity tester. Contact with the tank shall be made with the inside of the tank, or possibly at the lift lug, if steel is exposed, prior to application of the lift lug cover. No current shall pass through the factory installed flanged gaskets. Isolation of the fittings is required to assure tank integrity.

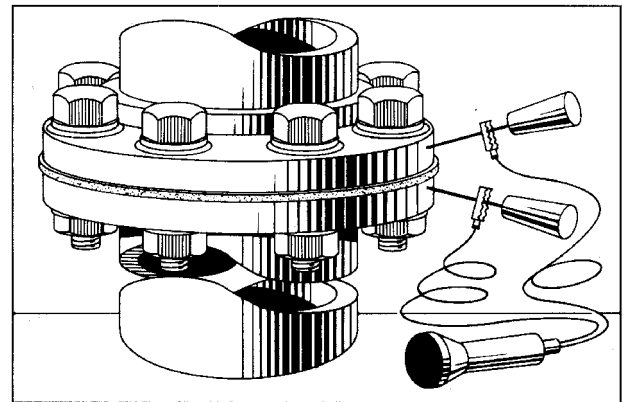

- 5.2 If a metallic hold-down strap is used, a pad of inert insulating di-electric material must be used to insulate the hold-down strap from the tank. The separating pad shall be wider than the hold-down straps, which will prevent direct contact between the straps and the tank shell. This pad is not required if the hold-down strap is fabricated from non-conductive material.
- 5.3 Ballasting the tank may be necessary. When water is used as the ballast material, it shall only be potable water and shall not remain in the tank longer than 60 days. During construction, adequately vent all tank spaces. If product is used as ballast, proper precautions must be taken to prevent fires, spills, leaks, and other associated accidents. Monitor product level frequently to ensure there has been no unaccounted loss of product. Do not over tighten hold-down straps beyond snug and do not re-tighten hold-down straps after ballasting.

6.0 BACKFILL

- 6.1 Homogeneous backfill material similar to the bedding material shall be carefully placed around the entire tank to create a uniform homogeneous environment. Avoid damage to cladding especially where tamping is required.

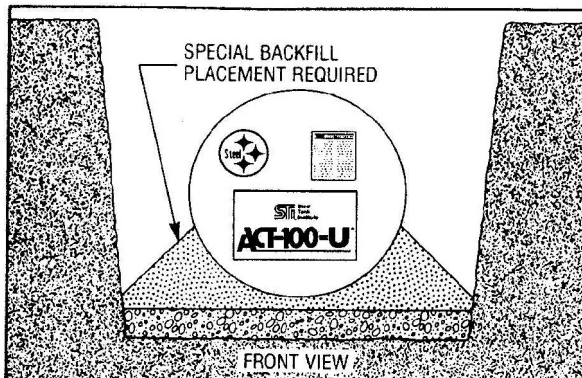

- 7.3 If the tank is to be installed in the presence of an impressed current system, the effect of the system must be considered on the ACT-100-U®. The corrosion consultant must consider including the ACT-100-U® tank into the design of the impressed current system.

8.0 FINAL AIR TEST

- 8.1 Install required tank piping using compatible non-hardening sealant, taking care not to cross thread or damage the nylon. Torque of 400 to 1,000 ft-lbs (542.3 to 1355.8 N-m) may be required to fully insert pipe.
- 8.2 Where air or hydrostatic testing is required after installation, the pressure applied shall not be in excess of 5 psig (34.5 kPa) as measured at the top of the tank. A soap solution shall be applied around pipe connections while air test is being performed.

9.0 SEALING OF PIPE CONNECTIONS, LIFTING LUGS AND REPAIRS

- 9.1 The fabricator, per STI specifications, has applied the cladding over all steel surfaces. During the installation process, steel can become exposed at the lift lug due to handling

- 6.2 Installing and tamping backfill along the bottom sides of the tank shall ensure that the tank is fully and evenly supported around the bottom quadrant.

of the tank. Steel may also be exposed at the interface between the steel tank and the electrical isolation fitting. These areas, along with all other exposed steel surfaces, must be covered via the touch-up kit supplied by the manufacturer. After application, the installer shall verify that the repaired area has cured (adequate material hardness and solidification) prior to backfill.

9.2 Clean areas to be repaired through removal of surface rust, dirt, contaminants, and disbanded cladding. The cladding surrounding all holidays, cladding flaw areas, and/or exposed steel areas should be surface prepared by using a coarse grit sandpaper or grinder. (Refer to SSPC SP-2 "Hand Tool Cleaning" or SP-3 "Power Tool Cleaning" for additional guidance). This process should remove all glossiness from the surface surrounding the repair area within 6 inches (152 mm) of the holiday.

9.3 After an air test has established tightness, tank fittings shall be covered with a coat of the repair material prior to backfill. (Refer to section 9.2 for surface preparation). Area to be coated shall include the entire plug on unused fittings.

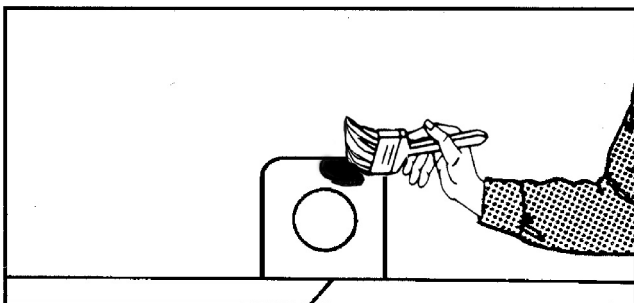

10.0 FINAL BACKFILL

10.1 Homogeneous backfill shall be deposited carefully around the tank and to a depth of at least 1 foot (305 mm) over the tank. (See NFPA 30 and state or local codes for minimum depth of cover required).

10.2 If cladding damage occurs after holiday testing or during backfill operation, repairs shall be made in accordance with Section 9.

11.0 OPERATING LIMITATIONS

11.1 Tanks shall be operated at ambient temperatures only.

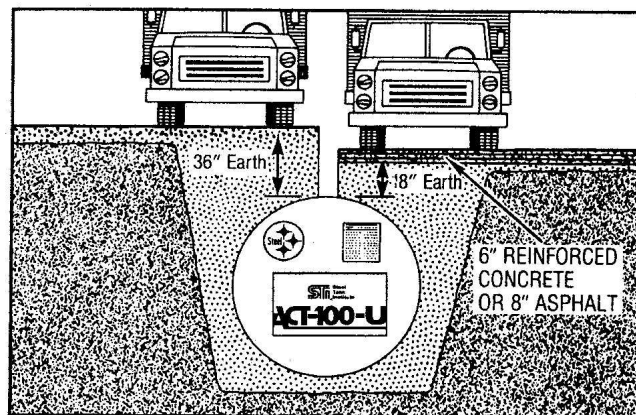

12.0 MAINTENANCE

12.1 The primary tank shall be inspected monthly for the presence of water. Inspection shall take place at the lowest possible points inside the primary tank. Remove any water found. Water and sediment in fuel can cause plugging of filters. Also, bacterial growth, originating from the fuel can cause filters to plug and corrosion of tanks and lines. For procedures on how to check for the presence of water and removal of water, refer to API Recommended Practice 1621, Appendix D and API Standard 2610. Another source of information is a report by the US Department of Energy, Brookhaven National Laboratory BNL 48406, which provides information on methods to test for and remove water, test for bacterial presence in fuel, tank cleaning and fuel additives.

12.2 Tank must be installed within one year of delivery from tank manufacturer. If tank is not installed within this time period, contact tank manufacturer to recertify the tank.

12.3* Safety considerations and controls should be established prior to undertaking physical activities associated with USTs. Some hazards associated with USTs are, but not limited to, confined space entry, cleaning, inspection, moving and any other aspect of in-service work.

12.3.1* Contact tank manufacturer before moving tank for information on recertifying tank for continued use.

DISCLAIMER

These instructions are intended only as an aid to tank installers who are knowledgeable and experienced in underground tank installation. Compliance herewith does not necessarily meet the requirements of applicable federal, state and local laws, regulations and ordinances concerning tank installation. STI makes no warranties, express or implied, including but not limited to, any implied warranties of merchantability or fitness for a particular purpose, as a result of these installation instructions.



R971-01

INSTALLATION CHECKLIST

MAY 2001

Owner of Tank: _____
Location of Tank: _____

ACT-100-U Label No: _____
Date: _____

CHECK ()

CHECK ()

HANDLING

the handling equipment is of adequate size and capacity to lift and lower the tank without dragging or dropping. _____

The repair of any damaged laminate areas has been made in accordance with installation instructions. _____

Prior to storage, the tank has been chocked with wood blocks or tires. _____

EXCAVATION

When no anchoring is required, the site has been excavated deep enough to enable 1 foot of clean sand or gravel to act as bedding material between native soil and tank. _____

Burial depths meet minimum code requirements (such as NFPA 30). _____

TESTING

The tank has been air-tested at 5 psig (kPa) while applying soap solution onto weld seams and fittings to check for leaks. _____

OR

on a double wall tank, vacuum test has been performed in accordance with the fabricator's instructions. _____

All local and state testing requirements have been performed. _____

ANCHORING

Not applicable to this site. _____

Deadman anchors used. _____

Concrete pad. _____

Soil and pavement over burden will hold down tank (reference PEI/RP100) _____

When anchoring with a concrete hold down pad, a minimum 6 inch (152.4 mm) layer of bedding material over the concrete pad dimensions to separate tank from pad. _____

When deadman anchors or hold down pads are used, hold down straps have been separated from the tank by an inert insulating dielectric material at least 1 inch (25.4mm) wider than the steel hold down straps. _____

Tank is electrically isolated from the hold down strap. _____

BACKFILL

Tank is buried with soundboard in place. _____

Homogenous backfill consisting of clean sand, pea gravel, #8 crushed stone or natural earthen material has been used. _____

Backfill is the same material as bedding. _____

Backfill has been placed along the sides of tank to ensure full support along the tank's bottom quadrant. _____

PIPE CONNECTIONS

Nonconductive piping used. _____

Dielectric bushings or flanges installed. _____

Signature and Title of Installing Foreman and/or Project Engineer

Installing Contractor

570 Oakwood Road
Lake Zurich, IL 60047
Phone: 847-438-8265
Fax: 847-438-8766



Note: This checklist includes certain key steps in the proper installation of the ACT-100-U tank and is intended only as an aid to tank Installers who are knowledgeable and experienced in underground tank installation. Compliance herewith does not necessarily meet the requirements of all applicable federal, state, and local laws, regulations and ordinances concerning tank installation.